



High Power Density Rack-Tower 2-IN-1
True Online Double Conversion UPS 1KVA-3KVA

Hercules-RT-IoT series Superior Group

★ General ★★ Better ★★★ Unique

System

- ★ - True online double conversion Topology
- ★ - DSP Control
- ★★★ - Site wiring check system
- ★★ - Communication ports: RPO, Dry in, Dry out, intelligent slot, USB, RS232

Performance

- ★★★ - Over Voltage Cut-Off device (OVCD) Up to 400 V.
- ★★★ - 1.0 Output Power Factor
- ★★ - Output THDv <1% linear load

Operation mode

- ★ - Normal Mode : Control V./ freq. sync. to line
- ★ - ECO Mode : via bypass within Programable range
- ★ - Freq. Mode : Control both V. & F.
- ★ - Start-able without battery (AC Start)

User Interface

- ★★ - High Efficiency ECO Mode
- ★★★ - Dot-matrix LCD, it support Multi-Language
- ★★★ - IoT: Ethernet(default) and Wireless (Optional)

WinPower View APP

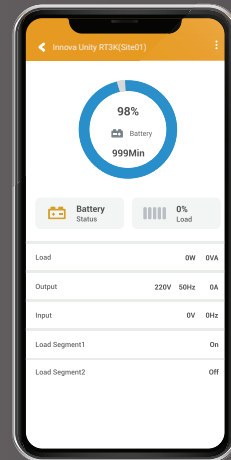
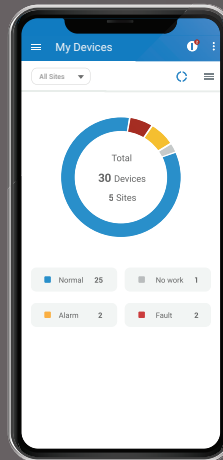

Scan this QR Code to
Download APP



for Android



for IOS

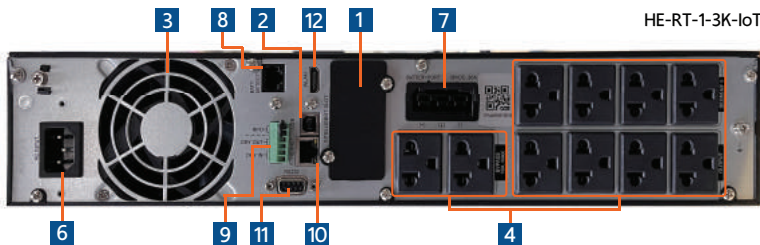

HE-RT-1-3K-IOT

- | | | |
|---------------------|--------------------|--------------------|
| 1. Intelligent Slot | 5. Circuit Breaker | 9. Dry In ,Dry Out |
| 2. USB | 6. Input Power | 10. Ethernet |
| 3. Coling Fan | 7. Battery Port | 11. RS232 |
| 4. Outlet | 8. Batt Detection | 12. WLAN |

Power Management Software

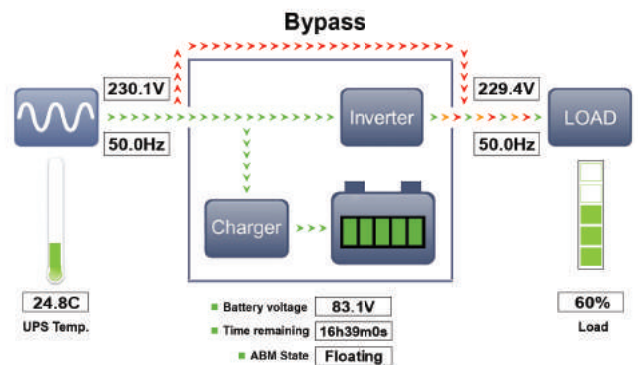

มอก. 1291 เล่ม1 - 2553
มอก. 1291 เล่ม2 - 2553
มอก. 1291 เล่ม3 - 2555



Syndome Electronics Industry Co.,Ltd.
66 ซอยประชาอุทิศ 59 แยก 3 แขวงบางนา เขตทุ่งครุ กรุงเทพฯ 10140
Tel: (662)8726900 (auto) Fax: (662)8726909
URL: <http://www.syndome.com> Email: public@syndome.com
Line: @syndome Facebook: www.facebook.com/official.syndome

Product Information

MODEL		HE-RT-1K-IoT	HE-RT-2K-IoT	HE-RT-3K-IoT
CAPACITY	VA/WATT	1K VA / 1000W(PF1)	2K VA / 2000W(PF1)	3K VA / 3000W(PF1)
INPUT	Voltage Range	160 ~ 300V 100% load, 110 ~ 160V derating to 50% load linearly		
	Frequency Range	50 / 60 Hz		
	Phase	Single phase with ground		
	Power Factor	>= 0.99		
	Generator Input	1.5 x UPS Rating Power		
OUTPUT	Voltage Range	200 / 208 / 220 / 230 / 240 Vac ± 1% (selectable)		
	Phase	Single phase with ground		
	Frequency Range	50 / 60 Hz		
	Current Crest Ratio	3:1		
	Harmonic Distortion	<1% Linear load; <4% Non-linear load		
	Protection	Short Circuit Protection		
	Output Waform	Pure Sinewave		
	Outlet	4 Thai Universal	8 Thai Universal	
	Overload Capacity	Line Mode	5 min @ 105%~125% ; 30 sec @ >125% ~ 150% ; 500 ms @ > 150%	
	Battery Mode			
EFFICIENCY	AC Mode	91%	93%	
	Battery Mode	>89%	>92%	
	ECO Mode	97%		
BATTERY	Number of Batteries	3	6	
	Battery Capacity (Ahr)	12V / (7/9)Ahr		
	Backup Time (depend on load)	>15 min		
	Recharge Time (to 90%)	3 Hours		
	Charging Current (Max.)	2A		
	Battery Type	Sealed Lead Acid Maintenance Free		
TRANSFER TIME	AC to DC	Zero		
INDICATOR	LCD	Input /Output information	Voltage / Frequency / Utility Present / Utility Lost	
		Load information	Amp / Watt / VA / Overload / Load level / % Load	
		Battery information	Voltage / Battery Level / % Battery / Remaining Time / Charging Mode	
		Mode information	Operating Mode Icon / Warning / Operating-Fault-Warning Message / Internal Temperature	
		Language	8 languages : English / Italian / French / German / Spanish / Russian / Polish / Simplified Chinese	
	LED	Line Mode(Green) / Battery Mode(Orange) / Bypass Mode(Orange) / Fault Mode(Red)		
ALARM	Battery Mode	Sounding every 4 seconds		
	Low Battery	Sounding every second		
	Overload	Sounding twice every second		
	Fault	Continuously Sounding		
DIMENSION	W x H x D mm	438 x 85.5 x 445	438 x 85.5 x 600	
WEIGHT	kg	9.4	22.2	
ENVIRONMENT	Operating Environment	0-40° C		
	Relative Humidity	0-95% (NON-CONDENSING)		
COMMUNICATION	Noise Level	<45dB @ 1 Meter	<50dB @ 1 Meter	
	USB	Software supports Windows Family, Linux, Sun Solaris, IBM AIX, Compaq True64, SGI IRIX, FressBSD, HP-UX and MAC		
	Dry Contact	RPO ,Dry in ,Dry out		
	IoT & Modbus TCP	Built-in ethernet port with Winpower View mobile app		
	Smart Slot (Option)	SNMP Adapter/ AS400 Relay Card / RS485		
INTERNATIONAL STANDARDS	Product standard	TIS 1291 Part 1-2553 , TIS 1291 Part 2-2553 , TIS 1291 Part 3-2555 Class C1		
	QMS	Certified Quality Management System ISO9001		
	EMS	Certified Environmental Management System ISO14001		



มอก. 1291 เล่ม1 - 2553
มอก. 1291 เล่ม2 - 2553
มอก. 1291 เล่ม3 - 2555



Syndome Electronics Industry Co.,Ltd.
66 ซอยประเวศรัถวิภา 59 ถนน 3 แขวงบางนาเหนือ เขตบางนา กรุงเทพมหานคร 10140
Tel: (662)8726900 (auto) Fax: (662)8726909
URL: <http://www.syndome.com> Email: public@syndome.com
Line: @syndome Facebook: www.facebook.com/official.syndome